



# THE Impact Ranking SDG17 Report

# 17

Partnerships for  
the goals



M. H. Mohameddin



## 1 National cooperation for implementation of SDGs

List of Ministries and National Directorates in the health sector that Pharos University cooperated with for implementing Students' community projects.

|   |                                  |
|---|----------------------------------|
| Alexandria Governorate  | Conferences and meetings         |
| Institute of Cultural Affairs   | Students Projects                |
| Education Directorate – Alexandria Governorate, Ministry of education | Community service projects       |
| Education Directorate – Beheria Governorate, Ministry of education    | Community service projects       |
| Health Directorate – Ministry of Health                               | Community service projects       |
| Cairo University  | Research                         |
| Alexandria University   | Research                         |
| Al Azhar University   | Research Project                 |
| Menia University  | Research Project                 |
| Academy of Science and Technology                                     | Research Project                 |
| High Institute of Public Health                                       | Research Project                 |
| Ministry of Health  | COVID Vaccination                |
| Arab Organization for Industrialization                               | Scientific research and training |
| Red crescent and blood bank   | Students Projects                |
| Alexandria Mineral Oils Company (AMOC)                                | Partnership                      |
| Petroleum Products Company (ASPPC)                                    | Partnership and training         |

**Below is the List of NGOs that Pharos University Cooperates with for Community Service Projects**

|   |                            |
|---|----------------------------|
| Egyptian Network for Research Ethics Committees   | Research Project           |
| Naba'a Al Hayat Foundation                        | Community service projects |
| Mojeeb Al Salayen Foundation                      | Community service projects |
| Al Staqrar Foundation                             | Community service projects |
| Kafalat Al Yateem Foundation at Fata neighborhood | Community service projects |
| Al Qalaa for Community Development.               | Community service projects |
| Eleen ElGaria association                         | Community service projects |
| Abdel Kadr Association                            | Community service projects |
| Tarek Charity Association (Mustafa Kamel)         | Community service projects |



|   |                            |
|---|----------------------------|
| Abu Masoud Suburb (Amiria)  | Community service projects |
| Ayadi Mostakbal medical center (NGO)                                      | Training                   |
| Omda Development Association (NGO)  | Students Projects          |
| Association of community based rehabilitation for disabled children (NGO) | Students Projects          |
| Red Crescent Association (Mohandeseen)                                    | Community service projects |
| Tarek ElKhair   | Community service projects |
| Al mutadarieun  | Community service projects |
| El Qalaa  | Community service projects |
| Kfalet El Yatem   | Community service projects |
| Nabaa El Hop  | Community service projects |
| El Estqrar  | Community service projects |
| Birla Carbon Egypt  | Student research project   |

## 2 Cooperation with the Private sector

The private sector is an important sector that Pharos university is keen to cooperate with for different purposes, mainly for meetings, conferences and workshops. Such meetings allow the recognition of new trends in the local and regional market and allow meeting the market needs. Below is the List of private sectors That Pharos University Cooperates with

| Company name                          | Type of cooperation         |
|---------------------------------------|-----------------------------|
| Eva Pharma                            | Participation in Conference |
| Innova Pharma                         | Participation in Conference |
| Hygint Pharmaceutical company Ltd.    | Participation in Conference |
| Goweily Academy                       | Workshops                   |
| Andalusia Hospital (Private Hospital) | Students activities         |



| Company name                                   | Type of cooperation      |
|--|--------------------------|
| El Youshr Hospital (private Hospital)          | Students Projects        |
| Fawzy Moaaz Hospital (Private Hospital)        | Students Projects        |
| Carrefour                                      | Partnership              |
| Easy Care Company                              | Partnership              |
| Mena For Touristic and Real Estate Development | Partnership              |
| IdeaSpace                                      | Student training         |
| Capital Professional Development               | Student training         |
| the Industrial Modernization Centre (IMC)      | Partnership and training |

## 2.1 Cooperation For SDG1

### 2.1.1 PUA celebrated Orphans Day with charity NGOs

PUA celebrated Orphans Day. The coordination was made between the Community Services and Environment Development Affairs and six charities NGOs:

- “Tarek ElKhair” Community Service, Sidi Gaber.
- “Al mutadarieun” Community Service, Rabaa El Nasria, Abis.
- “El Qalaa” Community Service, Awayed.
- “Kfalet El Yatem” Community Service, Ezbet Fathi.
- Nabaa El Hop” Community Service, El Hadra El Gadida.
- “El Estqrar” Community Service, Zawya Abd El-Qader, Al Amaria.



The ceremony was held at those charities. On 9th and 10th of April 2021, PUA formed six groups comprised of students, faculty members and coordinators of the student activities to visit those charities and give the orphans toys, gifts and clothes that had a good impact on children and staff. This activity is a part of the university's keenness to activate its role in developing the spiritual, moral and loyalty values of students as well as participating in community service.

### 2.1.2 Coordination with the Ministry of Social Solidarity and Alexandria Governorate [Humanitarian Aid Convoy to Abees District in Alexandria](#)

In coordination with the Ministry of Social Solidarity and Alexandria Governorate. It is worth mentioning that a large number of students from different faculties participated in this convoy. Prof. Hesham El Shimy, the Student Activities Leader and Prof. Ramadan Abo El Ala, the PUA Vice President.

Moreover, Dr. Jackline Azar, the Deputy Governor of Alexandria was keen to participate and follow up the proceedings of this convoy where she expressed her admiration for the university's activities in the field of community service and the





students' behavior.

<https://www.pua.edu.eg/pharos-university-sent-a-humanitarian-aid-convoy-to-abees-district-in-alexandria/>

## 2.2 Cooperation for SDG3

### 2.2.1 Cooperation with the Ministry of Health in the vaccination to combat Covid 19

The Egyptian government has made COVID-19 vaccination compulsory for students above the age of 18, faculty staff and other workers at both public and private universities. Egyptian-made Chinese Sinovac shots will be supplied to vaccination centers at university hospitals to vaccinate university workers, students and higher education staff before the beginning of the next academic year, in October. Each institute and research centre will also establish its own vaccination clinic.



## 2.2.2 Vaccination activities in Pharos University

Pharos University has put a plan for vaccination against Covid 19 of students and staff members, as well as community nearby the university premises.

The plan started on September 2<sup>nd</sup> 2021, where 2500 doses of Sinovac were received associated with special 0,5 cc sterile syringes. Each dose received is enough for two persons which makes these amounts sufficient to vaccinate 5000 persons.

The target number of persons to be vaccinated at the university for the local community is 14500 during the whole month of September with average daily dosages of about 232 recipients.

The vaccination work was extended till the middle of October to meet the targeted number and receiving more doses of vaccine that would be sufficient for all.

Vaccinating all members of the university community would improve the chances for a return to face-to-face educational activities.

However, returning to in-person education should not mean heading back to a hybrid education system. A new system “should continue on building” digital education, while adding the benefits of face-to-face activities

Waiting  
Hall





Reporting  
and check  
ups



Vaccination







List of governmental and Private hospitals in Alexandria and Beheria Governorates that cooperated with Pharos University for t students' raining and internships

| Hospital Name   | Purpose                  |
|---|--------------------------|
| Armed Forces Hospital- Mustafa Kamel                  | Internships              |
| International cardiac center ICC                      | Training anf Internships |
| General Military Hospital                             | Internships              |
| Faculty of Medicine Hospital of Alexandria University | Training and research    |
| Andlusia Hospital                                     | Training                 |
| NAPHS   | Online Training          |
| 57375 Hostital  | Students activities      |

### The Faculty of Arts and Media Blood Donation Campaign

The Faculty of Arts and Media in collaboration with the Faculties of Legal Studies, Engineering, Pharmacy and Dentistry organized a blood donation campaign on Tuesday, March 15th, 2022. The event was organized within the framework of PUA's participation in community service activities. The event started at 11 am with the arrival of a blood donation vehicle from the Blood Bank. The campaign was met with an overwhelming turnout of students, while the faculties cooperated in organization and motivation of the students.

<https://www.pua.edu.eg/%d9%83%d9%84%d9%8a%d8%a9-%d8%a7%d9%84%d9%81%d9%86%d9%88%d9%86-%d9%88%d8%a7%d9%84%d8%aa%d8%b5%d9%85%d9%8a%d9%85-%d8%aa%d9%86%d8%b8%d9%85-%d8%ad%d9%85%d9%84%d8%a9-%d9%84%d9%84%d8%aa%d8%a8%d8%b1%d8%b9/>

## 2.3 Cooperation for SDG4

### 2.3.1 PUA signed a cooperation protocol with IdeaSpace for students training

<https://www.pua.edu.eg/pua-and-ideaspace-sign-a-cooperation-protocol/>

In implementation of its field training plan, PUA signed a cooperation protocol with IdeaSpace Company, which represents the “Egypt Makes Electronics” initiative (EME) of the Information the Information Technology Industry Development Agency (ITIDA) to train PUA’s students.

### 2.3.2 Pharos university participates in “Egypt Make Electronics” initiative (EME)

<https://www.pua.edu.eg/education-development/>

In recognition of the Faculty Applied Health Sciences Technology and the Department of Biomedical Equipment Technology of the necessity of developing education through linking the academic activities with the Egyptian industrial initiatives.

Based on coordination made by Asst. Prof. Dr. Mohamed Ismail Badawy, Head of the Department of Biomedical Devices Technology; *and*

In response to the invitation extended by “Egypt Make Electronics” initiative (EME), which is funded by the Information Technology Industry Development Agency (ITEDA), of the Ministry of Communications,

17 Department students along with five faculty members and teaching assistants visited EME’s Innovation Hub-Borg Al Arab. The visit aimed to identify



the possibilities available, and to open horizons for the Department students to implement their graduation projects.

As a result, the students learned about the initiative’s capabilities and its advanced laboratories, such as printed circuit laboratories, manufacturing laboratories, artificial intelligence laboratories, and Internet of Things laboratories.

### 2.3.3 cooperation protocol with Capital Professional Development for training of the students of the faculty of Languages and Translation

<https://www.pua.edu.eg/pharos-university-signed-a-cooperation-protocol-with-capital-professional-development/>

In the light of the field training plan set for the faculty of Languages and Translation, Pharos University signed a cooperation protocol with Capital Professional Development on Monday, 1 February 2021. It is worth mentioning that the protocol aims to train the students of the faculty of Languages and Translation.

It has been agreed upon training almost 100 students in 6 days in the following topics: Human Resources, Customer Service and Marketing. The students will be evaluated on group projects after each training topic and they will receive certificates after finishing the field training course.

### 2.3.4 A visit to Ayady ELMostabal Foundation

Ayady ELMostakabal is NGO aiming at helping Children diagnosed with cancer , Pharos university is in active partnership with the organization and support their activities via donations and other means of cooperation





List of governmental and Private Companies that cooperated with Pharos University for t students’ training and internships

|   |   |
|---|---|
| Egyptian Projects Operation & Maintenance   EPROM   | Faculty of Engineering                      |
| Alexnadria company for electricity                  | Faculty of Engineering                      |
| Egyptian Ethylene and Derivatives Company (ETHYDCO) | Faculty of Engineering                      |
| Mosahamet El Behera                                 | Faculty of Engineering                      |
| ETM. Agriculatural Service                          | Faculty of Engineering                      |
| SEDIkrirl for petrochemicals SEDPEC                 | Faculty of Engineering                      |
| WE, ELmasryaa for communications                    | Faculty of Engineering                      |
| Arab African company                                | Faculty of Engineering                      |
| XYPEX   | Faculty of Engineering                      |
| RUNPeoff LLC  | Faculty of Engineering                      |
| DI GI print   | Art and designs                             |
| Alex Apparels                                       | Art and designs                             |
| Monarch Materials                                   | Art and designs                             |
| Attorneys syndicate                                 | Legal Studies and international cooperation |
| Elzahraa language school                            | Languages and translations                  |
| Capital professional development                    | Languages and translations                  |
| HSH Education company                               | Languages and translations                  |
| EG Bank   | Financial and administrative science        |
| Knowledge officer company                           | Financial and administrative science        |

## 2.4 Cooperation for SDG6

### 2.4.1 Pharos university Contributions in the “Live Green”Presidential Initiative

<https://www.pua.edu.eg/pharos-contributions-in-the-live-green-presidential-initiative/>

The Vice President of Community Service and Environment Development Affairs and the Director of the Community Service and Environmental Development Centre (CSED) participated in a meeting about the “Live Green” initiative. The meeting was held in Alexandria Governorate Office on Wednesday, 12 February 2020.





The aim of the meeting is to discuss the mechanisms to apply the “Live Green” initiative launched by the President of Egypt.  
<https://english.ahram.org.eg/NewsContent/1/64/362323/Egypt/Politics-/Egypts-Live-Green- initiative-reflects-the-states-c.aspx>

The meeting was attended by the Deputy Governor of Alexandria and representatives from all concerned authorities in the governorate. During the meeting, Mr. Ahmed Gamal stressed the importance of the consultative role of Pharos University which came within the framework of the government keenness to achieve cooperation and integration by taking advantage of the experiences of the scientific bodies in Alexandria and working hand in hand for the benefit of the governorate.

In addition, Prof. Hesham El Shimy showed the attendees a study on “Harmonic Mechanisms for Treating all Types of Wastewater to Irrigate a Sustainable Green Belt to Protect the Vicinity of Lake Mariout.” It is worth mentioning that the study impressed all the attendees and it was stressed upon the need for adopting that study.

## 2.5 Cooperation for SDG7

### 2.5.1 Production of Biojet fuel a project in line with the sustainable development goals and Egypt 2030.

The Petrochemicals Department at the Faculty of Engineering carried out a study aiming at designing a reactor for the production of biofuel using hydrodynamic cavitation technique. This technique is based on intensifying the rate of the reaction and the production of biofuels from non-edible oil by introducing bubbles to the liquid. A model was constructed to t explains this process and validate it using experimental data. The reactor has already been implemented successfully and experiments have been conducted to test to prove its effectiveness. This clean biofuel is considered as an alternative to fossil fuel used in industry, in aviation in addition to avoiding the negative impacts of fossil fuel combustion.

| NO. | DESCRIPTION               | NO. | DESCRIPTION                      | NO. | DESCRIPTION                |
|-----|---------------------------|-----|----------------------------------|-----|----------------------------|
| 01  | BIO FUEL                  | 06  | MECHANICAL STAINLESS STEEL SHAFT | 11  | TRANSPARENT STATOR         |
| 02  | SEPARATION HOPPER         | 07  | HIGH SPEED BEARING               | 12  | 8M THREADED BOLT WITH NUTS |
| 03  | GLYCERIN                  | 08  | SAMPLING POINT                   | 13  | PERISTALTIC PUMP           |
| 04  | ELECTRIC MOTOR (5000 RPM) | 09  | GATE VALVE (ISOLATION)           | 14  | FLANGE                     |
| 05  | FLEXIBLE SHAFT COUPLING   | 10  | CYLINDRICAL ABSORBER             | 15  | MAGNETIC STIRRER           |

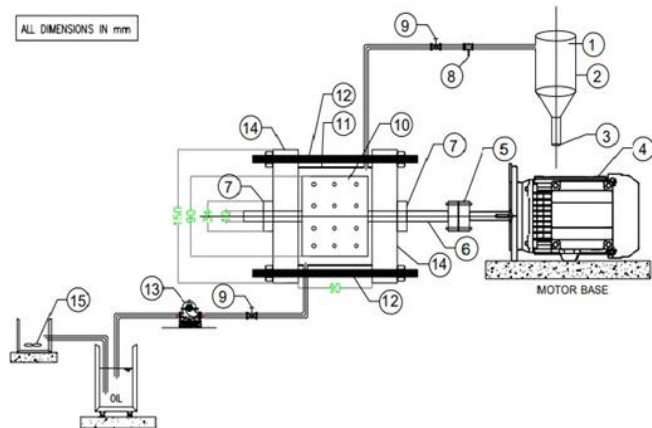

The production of an alternate source such as bio jet fuel can be a viable sustainable option, based on non-edible oils, and inline with the sustainable development goals and Egypt 2030. The development of bio jet fuel from renewable sources would not only reduce the reliance on fossil fuels, but also can potentially reduce CO<sub>2</sub> emissions by up to 68.1% in 2050. Hydrodynamic cavitation can be effectively used for the intensification of interesterification reaction for the synthesis of bio jet fuel and glycerol.



## 2.6 Cooperation for SDG 8

### 2.6.1 Fifth job fair of the Faculty of Tourism and Hotel Management.

Prof. Dr. Mahmoud Mohy El-din, PUA's President, launched the Fifth job fair, which was organized by the Faculty of Tourism and Hotel Management.

This fair comes within PUA's endeavor to provide job opportunities for its graduates, and to implement training partnerships with various tourism companies and hotel chains in Alexandria.

The fair witnessed a large presence of industry men and Faculty's cooperation partners, represented by 20 tourism companies and hotels.

As well as representatives of the Ministry of Tourism and the Tourism Promotion Authority in Alexandria.

Accordingly, the Faculty administration extends its sincere thanks and appreciation to all those who thankfully participated in the job fair. As well as for the support provided to promote the level of training in the Faculty and facilitating the graduates' access to proper job opportunities.





## 2.7 Cooperation for SDG 9

### 2.7.1 Cooperation with industrial Modernization Centre (IMC) in providing solutions to some of the problems encountered by the industrial sector in Alexandria

<https://www.pua.edu.eg/pharos-university-to-foster-ties-with-the-industrial-modernization-centre/>

Prof. Ramadan Abu El-Ala, the Vice President of Community Service and Environment Development Affairs, along with Prof. Hana Yassin, the Dean of the Faculty of Arts and Design- Pharos University held a meeting with some representatives of both branches of the Industrial Modernization Centre (IMC) in Cairo and Alexandria. During the meeting, means of cooperation were sought between Pharos University on one side and the Industrial Modernization Centre (IMC) and the whole industrial sector in Alexandria on the other side, in concern with the realm of field training as well as the implementation of the students' graduation projects. It was also discussed the possibility of the participation of Pharos University in providing solutions to some of the problems encountered by the industrial sector in Alexandria. At the end of the meeting, Prof. Ramadan Abo El-Ala called for another meeting between Pharos University and the Industrial Modernization Centre (IMC) to work on achieving the goals of the community service sector in Pharos University and finding solutions for the problems of the industrial sector in Alexandria.

### 2.7.2 Cooperation Protocol between Pharos University and Arab Organization for Industrialization

<https://www.pua.edu.eg/cooperation-protocol-between-pharos-university-and-arab-organization-for-industrialization/>

The protocol included the possibilities of joint cooperation in the fields of scientific research, training and participation in solving technical problems for the sake of carrying out research and patents and benefiting from the scientific and human capabilities at Pharos university and the Arab Organization for Industrialization. The delegation was received by Prof. / Mahmoud Mohy Al-Din – President of the University, Prof. / Ramadan Abu Al-Ela – Vice President for Community Service and Environmental Development Affairs, Prof. / Mohammed Gabar Abo Ali Faculty of Engineering Dean, Prof. / Mohammed Naem Faculty of Engineering Vice Dean, and Prof./ Mohammed Yahia Al-Makki Professor at the Faculty of Engineering, and a number of teaching staff committee at the faculty.



Both parties agreed on the optimal use of the resources to move to the rank of developed countries and achieving the developmental desired aims of the Egyptian society and to accomplish the above the both parties signed a cooperation protocol signed by Prof./ Mahmoud Mohy El-Din as a Pharos University President Also Major General/ Ahmed Abdel Aziz – authorized by Lieutenant General chairman of the organization.

### **2.7.3 Protocol on Cooperation Between PUA and Alexandria Mineral Oils Company (AMOC)**

<https://www.pua.edu.eg/protocol-on-cooperation-between-pua-and-alexandria-mineral-oils-company-amoc/>

The meeting and the signed protocol have tackled the prospects of mutual cooperation in training fields, and participation in solving the technical issues, to which PUA can contribute in finding practical solutions. Accordingly, both parties have agreed on making optimal use of their respective capabilities in a manner compliant with the state's strategy in terms of connecting industrial institutions and productions sites, with the Egyptian Scientific and Academic Institutions to achieve the developmental objectives of the Egyptian society. To achieve that, a protocol on cooperation has been signed by Prof. Dr. Ramadan Abu Al Ella, as PUA's Vice-president for Community Services and Environment Development and Chem. Ehab Ahmed Abdul Halim, as Chairman and Managing Director of Alexandria Mineral Oils Company (AMOC).

### **2.7.4 PUA Signs a Protocol on Cooperation with Alexandria Specialty Petroleum Products Company (ASPPC)**

<https://www.pua.edu.eg/pua-signs-a-protocol-on-cooperation-with-alexandria-specialty-petroleum-products-company-asppc/>

A high-ranking delegation of Alexandria Specialty Petroleum Products Company (ASPPC) visited PUA. The delegation was headed by Chem. Dr. Mosaad Attia Al Qasabi, Chairman and Managing Director. The delegation was hosted by Prof. Ramadan Abu El-Ala, Vice President of Community Service & Environment Development Affairs, Prof. Dr. Prof. Mohamed Gaber Abou Ali, Dean of the Faculty of Engineering, Prof. Dr. Gamal Elbhery, Dean of the Faculty of Computer Science & Artificial Intelligence, Prof. Dr. Mohamed Yahia Al Mekki, Professor of Engineering, and a number of faculty members of the Faculty of Engineering.

Both parties discussed mutual cooperation possibilities in training fields, and participating in solving the technical issues, to which PUA can contribute in finding practical solutions. Thus, the parties agreed on the necessity of the



optimal use of each party's available capabilities in a manner compliant with the state's strategy in terms of connecting the industrial institutions with production sites, and the Egyptian scientific and academic institutions to achieve the developmental objectives of the Egyptian society. To this end, both parties agreed on a protocol on cooperation that was signed by Prof. Dr. Mahmoud Mohy El-Din, as PUA President and Chem. Dr. Mosaad Attia Al Qasabi, as Chairman and Managing Director of Alexandria Specialty Petroleum Products Company (ASPPC).

### **2.7.5 Cooperation Protocol between Pharos University and Arab Organization for Industrialization**

Arab Organization for Industrialization visited Pharos University (P.U.A), and the delegation was headed by Major General /Ahmed Abdel Aziz – chairman of the board of directors of the electronics factory in the organization. The delegation included Dr. Essam Mansour – Advisor to the chairman of the board of directors of the electronics factory and Eng. Ashraf Khalil – head of the Human Resources sector. The two parties discussed the possibilities of joint cooperation in the fields of scientific research, training and participation in solving technical problems for the sake of carrying out research and patents and benefiting from the scientific and human capabilities at Pharos university and the Arab Organization for Industrialization.





## 2.8 Cooperation for SDG 11

### 2.8.1 Pharos university in The First Egyptian Hackathon for Smart Cities <https://www.pua.edu.eg/department-of-electrical-engineering-in-the-first-egyptian-hackathon-for-smart-cities/>

The Department of Electrical Engineering have participated in the activities of the first Egyptian Hackathon for Smart Cities at the national level. The event was held at Benha University from March 24 to March 26, 2022 under the patronage of His Excellency the Minister of Higher Education and Scientific Research, and in partnership with the Amazon Web Service.

Benha University, as the organizer of the event, announced that 478 teams representing 50 Egyptian public, private, and national universities applied to participate in the hackathon. The teams were later shortlisted to only 40 teams representing 25 universities.

The electrical engineering department team was chosen as the sole representative of Pharos University. The team includes five students from the fifth year, namely: Mohamed Abdel Azeem, Fayza Abdel Fattah Mohammad, Ahmed Khalil, Seif El-Din Mahmoud, Mohammad Ali Ahmed. Further, the project presented was supervised by Prof. Dr. Ahmed Abdullah. The team is also accompanied by Eng. Abdul Rahman Khaled, teaching assistant, as a supervisor.

### 2.8.2 Participation of the Architectural Department in The Competition of Designing Kiosks at Al Azbakiya Park Within the Project of Developing the Garden

Within the framework of the government efforts in the development of the old Cairo area to revive., conserve and restore buildings, in addition to the development of urban areas , to serve pedestrians and transportation in their various forms that serve the society, and including the development of al Azbakiya Park, where the park occupies an urban site linked to most of the important squares of the city center.



In order to encourage the role of youth, the Department of Architecture at Pharos University in Alexandria has participated with six teams of different





academic levels, where three of them were qualified for the finals within different universities in the keenness of the Department of Architecture at Pharos University to develop the capabilities of students and participate effectively in community service.

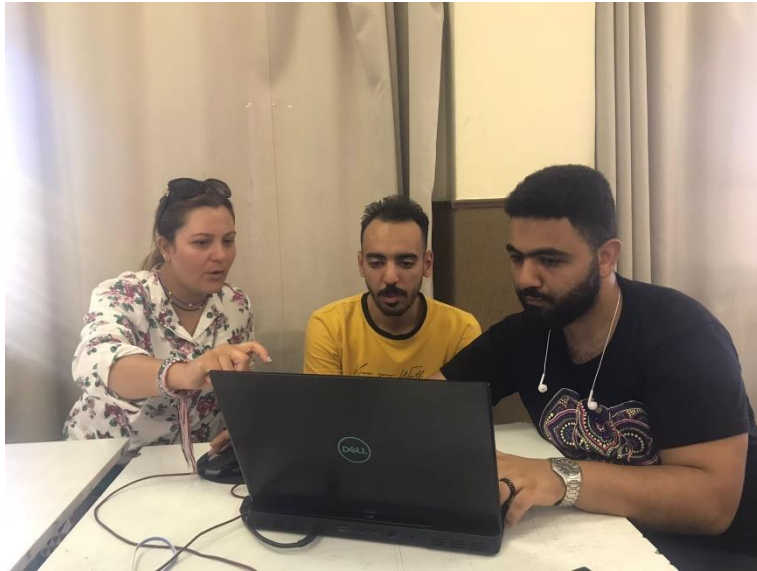



## 2.9 Cooperation for SDG 13

### 2.9.1 Pharos university organize a student's sustainable projects competition with cooperation with Birla Carbon Egypt

The faculty of Engineering organized the “Towards Sustainable Tomorrow” competition sponsored by Birla Carbon Egypt for the third year in a row. This was held on Tuesday, 28 July 2020. The competition aims to choose creative projects that serve sustainability. The value of 36000 LE was allocated for the awards of the first three places: 17000 LE for the 1<sup>st</sup> place, 12000 LE for the 2<sup>nd</sup> place and 7000 for the 3<sup>rd</sup> place. It is worth mentioning that 6 projects participated in this competition from [Electrical Engineering, Mechanical Engineering, Petrochemical Engineering Departments](#).

The electrical engineering project “IoT Approach for Sustainable Green Campus” won the 2<sup>nd</sup> place in the competition. It was submitted under the supervision of Dr. Mohammed Adb El Karim.

Petrochemical Engineering Department participated with 2 projects:

- “Synthesis of Ion Exchange Resins for Ammonia Removal Based on Waste Polymers” which was submitted under the supervision of Dr. Rania Farouk.
- “Recycling of Polyester Fabric Scraps” won 3<sup>rd</sup> place in the competition. It was submitted under the supervision of Dr. Ehsan Nafed.

Mechanical Engineering Department participated with 3 projects:

- “Design, Modeling and Performance Analysis of Solar Still” which was submitted under the supervision of Dr. Mohamed El Saied Youssef.
- “Design and Optimization of Network Solar” won the 1<sup>st</sup> place in the competition. It was submitted under the supervision of Dr. Mohamed El Naqib.
- “Home Scale Vertical Axis Wind Turbine (VAWT)” won the 2<sup>nd</sup> place in the competition. It was submitted under the supervision of Dr. Sameh Tawfik.





## 2.9.2 Pharos university participate in a conference discussing Climate Change effects on Alexandria, Organized by Alexandria university

<https://www.pua.edu.eg/climate-conference-2/>

<https://www.pua.edu.eg/media-and-climate-changes-seminar/>

A high-level delegation from Pharos University participated in the “Future of Alexandria and Climate Challenges” conference held at the Bibliotheca Alexandrina on Tuesday, March 29, 2022, which was co-sponsored by Pharos University. The delegation included Prof. Dr. Mahmoud Mohy El-Din, President of the University, Prof. Dr. Prof. Nourhan Fanaky, Vice-President for Education and Student Affairs, Prof. Dr. Prof. Ramadan Abu El-Ala, Vice President of Community Service & Environment Development Affairs, Prof. Dr. Boshra Salem, Dean of Postgraduate Studies and Research, and Prof. Dr. Ramadan Abdel Maksoud, Supervisor of the Department of Architecture, Faculty of Engineering, along with a number of university students. Further, the delegation members participated in the important discussions and recommendations produced from the sessions held in this regard.



### 2.9.3 Pharos university organizes a seminar on seminar on “Media and Climate Change in the Light of the Sustainable Development Goals” with participation of several local media experts

<https://www.pua.edu.eg/media-and-climate-changes-seminar/>

PUA’s Faculty of Mass Communication organized a seminar on “Media and Climate Change in the Light of the Sustainable Development Goals”. This seminar tackled the following topics:

1. Climate changes and how to adapt to them.
2. Urgent actions to address climate change.
3. Alexandria and the fate of disappearance.
4. Rising temperatures and their impact on coastal cities.
5. Sustainable development and climate fluctuations.
6. The role of media and social media in educating the public about climate change and their effects on all aspects of life.

Further, the seminar hosted a group of environment and media experts, namely: Dr. Mahmoud Bakr, Deputy Editor-in-Chief of Al-Ahram Weekly and Head of the Environment Department. Dr. Ramy Yacoub, United Nations Industrial Development Consultant and Director of the European Union and Earth Climate for Sustainable



Development Foundation’s Climathon Egypt Project, Dr. Mamdouh Rashwan, Secretary-General of the Arab Union for Environmental Affairs and President of the Egyptian Youth Association for Development & Environment (YADE). Dr. Saber Mohammed Othman, Climate Change Expert and Chairman of the Board of Trustees of Climate Earth Climate for Sustainable Development Foundation’s, Dr. Sameh Riyadh, Head of the Environmental Affairs Authority in Alexandria Governorate. Prof. Hassan Baraka, Assistant Editor-in-Chief and Environmental official at Al-Akhbar Newspaper. Prof. Fawzy Abdel Halim, former Editor-in-Chief and Head of Environment Department of Al-Ahram Newspaper. The seminar



aimed to educate students about the climate change crisis and its effects on the future of upcoming generations.

This seminar was moderated by Dr. Mahmoud Bakr, Deputy Editor-in-Chief of Al-Ahram Weekly and Head of the Environment Department at Al-Ahram. The guests presented several visions on different topics.

### **Students' community service projects**

The community service project is an annual curricular project for all students. The project is aiming at helping the community by providing services that address sustainable development goals. Each scientific department designs a project for a group of students. The projects are evaluated by a general committee every year for the winning projects

<https://www.pua.edu.eg/60116/>

the student projects for 2020-2021 were summarized in this report

### **3 For SDG 3 the students the students participated in the following project “Factors affecting COVID-19-related health literacy in Egyptian population”**

The aim of this project is to assess coronavirus-related health literacy in Egyptian population and to increase their awareness about preventing the spread of COVID-19 virus.

- Specific Objectives
  - A. Measure Patient's health literacy regarding the disease
  - B. Examine the differences in health literacy in relation to age, gender, education level, professional background being medical or non-medical, and socioeconomic factors.
  - C. Provide evidence-based information to the enrolled participants about the protective measures required to stop the spread of the COVID-19 virus and answer their enquiries about this topic.

### **Subjects and methods:**

This cross-sectional study was done in Egypt during the second wave of COVID-19 pandemic. It represents a population-based survey on comprehensive health literacy in relation to coronavirus information and it uses the adapted HLS-EU-Q in the context of the COVID-19 to assess coronavirus-related health literacy. It also tests COVID-19-related health literacy in individuals in relation to feeling informed or confused about COVID-19 by the high flow of information about the COVID-19. Each item of the questionnaire was rated on a four-point Likert scale (very difficult, difficult, easy, and



very easy). “Very difficult” was scored as 1 “difficult” was scored as 2, “easy” was scored as 3, and “very easy” was scored as 4. Scale values were calculated as summed scores.

### 1) Sociodemographic Questions:

Participants were asked about their gender, age, education, household monthly income, and occupation (medical versus non-medical background).

### 2) Information or Confusion about the Coronavirus

### 3) Health Literacy assessment

- Mean score of <2.5: “inadequate health literacy”
- Mean score of 2.5–3: “problematic health literacy”
- Mean score of >3: “sufficient health literacy”

4) Questionnaire tools was translated from English into Arabic by an independent Arabic native speaker, and later back translated by a second translator to establish a version (semantically, conceptually, and experientially) equivalent to the original one. The retro-translation gave rise to no differences.

### Second phase: Questionnaire filling

The survey was done via participants interviews in spring 2020-2021. Students were divided into groups for questionnaire sample collection using stratified random sampling technique. They were divided according to the criteria of participants enrollment into 16 groups that represent the diverse Egyptian population, Where each student applied face-to-face interviews with 10 participants. The survey included male and female participants from Egypt. Each student filled the gathered information later in a Google form.

Third phase: Increasing population awareness about COVID-19 pandemic

Fourth phase: Statistical analysis:

Ethical approval:

Ethical approval was granted by the ethics committee of the faculty of pharmacy, Pharos university in Alexandria, Egypt (Study number: PUA01202106203024)





## Conclusion:

There is a great need to promote health education among the Egyptian population. Limited health literacy which includes problematic and inadequate health literacy is a common problem. More than half of the Egyptian population has inadequate or problematic COVID-19 related health literacy score. Female gender, younger age, higher socioeconomic status, professions with medical background, and level of education were positively correlated to COVID-19 related health literacy. It is important that the government, policymakers, healthcare providers, and media act proactively to increase the level of the citizens COVID-19 related health literacy.

### **3.1 “The Baby Safe mattress”**

The Baby Safe mattress. It is a medical mattress for children, the purpose of which is to protect the child from any emergency situation, whether it is an increase in the child’s temperature, an irregular heartbeat, or a decrease in the level of oxygen in the blood through sensors located in the mattress. It issues alerts to the mother through a loudspeaker or through the mother or father’s phone by downloading a special program for the mattress to inform them periodically about the health of their child.

#### **Aim of the Research Project (baby safe):**

One of the goals of serving working women and providing family safety is that the research project aims to provide comfort for the mother and father and safety for the child by following up on his health status during sleep or waking up and making sure that the child’s condition is safe through the sensors in the rank that constantly send updates on the child’s condition. The application is available on the parents’ phones, and if an error occurs in the child’s pulse, oxygen, or temperature, alerts are sent to the mother or father’s phone to inform them of the location of the defect.

#### **Stages of Carrying out the Research Project (baby safe): -**

- 1-After suggesting the idea among the work team members
- 2- It was implemented in a maquette that expresses and about the sensors and the sounds of alerts that come out of it to warn about something that is happening
- 3- A website has been created for the product to be sold on the Internet
- 4- Create pages on social networking sites (Facebook and Instagram) to





promote the product and explain it to the consumer

5- Proposing sales development plans for the product, for example: by making contracts with outlets selling children's products to display our product in their showrooms

### 3.2 (Implementing "Dental Traumatic Injuries Educational Program" Among teachers of different Governmental Elementary schools in Alexandria, Egypt.)

#### The aim of this study was to:

- Assess the level of knowledge of the governmental elementary school teachers about TDIs & their management, using questionnaires.
- Awareness about TDIs emergency management through implementing an oral health educational program to the same target group.
- Traumatic Dental Injuries (TDIs) are a serious dental public health problem among children (International Society of Preventive & Community Dentistry, 2019). It can vary from a minor tooth fracture to extensive maxillofacial damage. Oral injuries are the fourth most common area of bodily injuries.
- The prevalence of Traumatic injuries in permanent teeth have been reported to exceed 60%. In Egypt, a study was conducted by ElKelany M. et al concluded that the most common areas of TDIs among children were at school (50%) then at home (30%); this was mostly due to increased predisposition of accidents, fights & sports traumas at school age.

#### ❖ Recommendations:

- We recommend implementing a dental traumas awareness program at different schools in Alexandria.



- Also, to provide an emergency dental unit at PUA outpatient clinics (PUA trauma center); furthermore, establishment of trauma hotline to provide teachers with appropriate management in case of TDIs emergency.

### 3.3 Assessment and Intervention Program to Raise Nutritional and Health Awareness of Females in the Reproductive Age and their children in Alexandria Rural Area "Houd 10"

#### ❖ Project Aim:

- To assess the nutrition status and awareness of rural women.
- To assess the nutritional knowledge and the awareness of rural women.
- To conduct nutrition education program to raise the awareness of the rural women in the target areas.
- To evaluate the nutritional knowledge and the awareness after intervention program.

#### ❖ Project Summary:

- Project Idea: Assessment of nutrition status of rural women to tackle any nutritional problems and evaluation of their nutritional knowledge aiming at providing targeted educational sessions to raise their awareness and improve their nutritional knowledge.
- Project Phases: The project was carried out in three phases

#### Phase I:

1. Designing a questionnaire to measure the nutritional knowledge and awareness of rural women in Houd 10
2. Taking the approval from stakeholders (CAPMAS, Ministry of social solidarity, and National Security agency)

#### Phase II:

- Collection of data (interviewing of the women, anthropometric measurements, and laboratory investigations)

#### Phase III:

- Designing and implementing educational programs through conducting awareness seminars in Houd 10 (rural area) through illustrative posters and lectures
- Recollecting data through post-intervention questionnaire to assess the changes in the nutrition knowledge of the rural women

#### 4 For SDG 11 the students participated in the following projects

##### 4.1 PREPARING DETAILED PLANS FOR SLUMS IN ALEXANDRIA GOVERNMENT

Regarding the cooperation through technical and academic support for the urban planning and development system to improve the environment and achieve sustainable development goals and within the framework of fruitful cooperation between Pharos University and the Governorate of Alexandria to activate its pioneering role in the Alexandrian society, detailed plans were prepared for the two areas

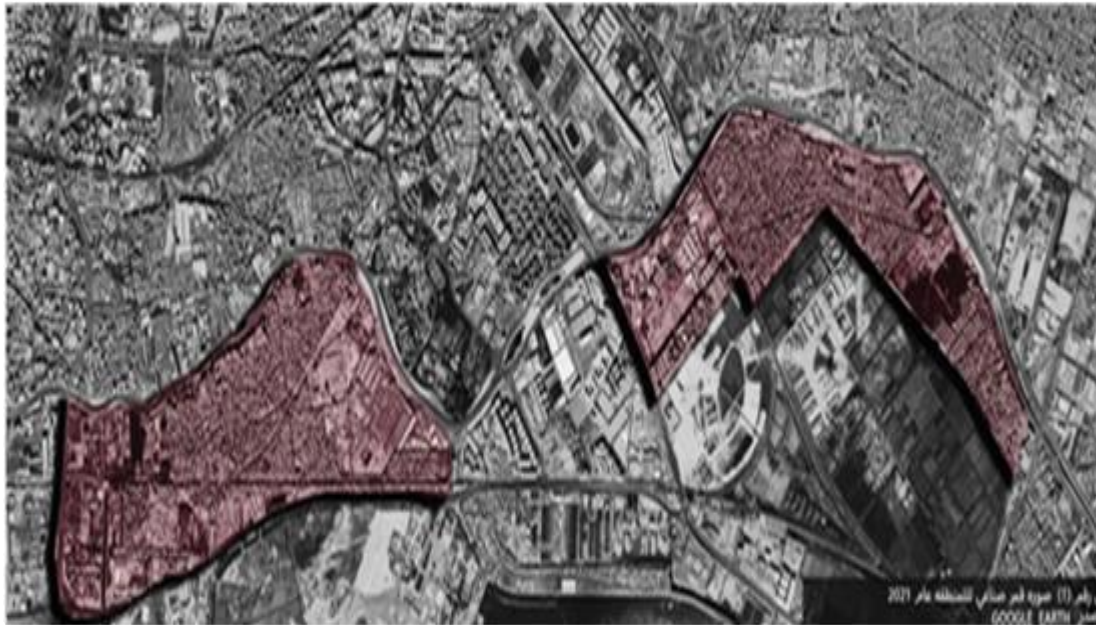

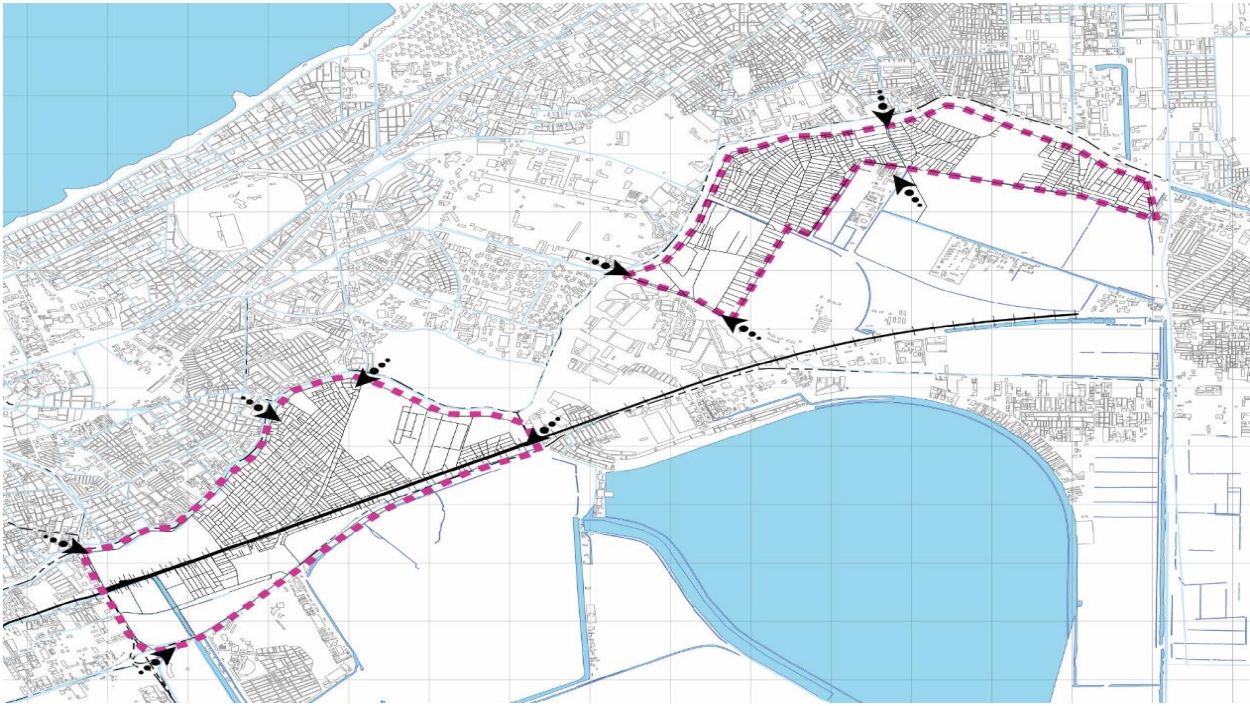



The Department of Architectural Engineering, which is in charge of implementing the plan assigned to it, executed and prepared a detailed report for the two areas and the future vision for them and presented the outputs of the proposed master plan suggesting a proposal for the development of these two areas through several development axes based on the future vision represented by a number of projects in the development of residential areas and lands, in a report containing 85 pages, in addition to 25 geographic information systems (GIS) maps.

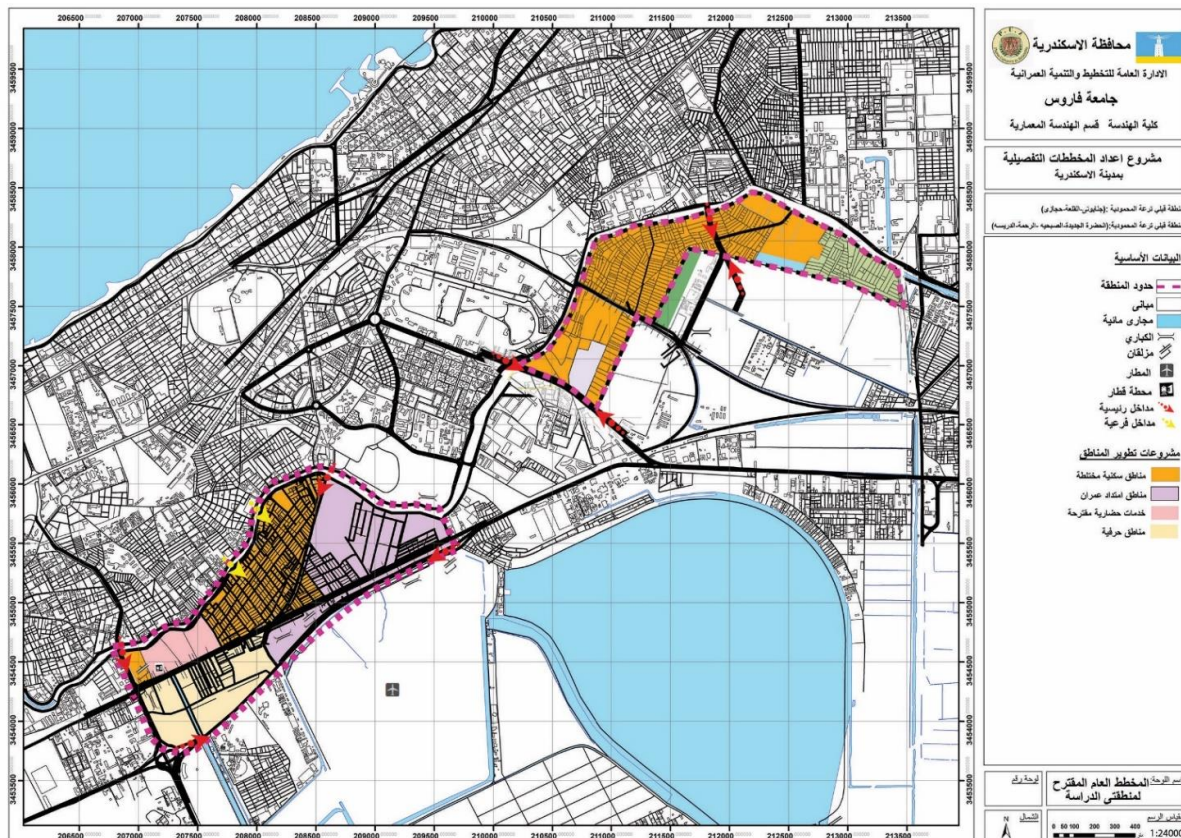

## 4.2 Designing shaded waiting benches on campus

### ❖ Introduction:

Universities with open spaces need seating areas for students and visitors within the campus square. These seatings must be shaded to provide protection and shelter to users from weather fluctuations, whether intense sunlight or rain especially after COVID19 pandemic regarding applying the precautionary measures and keeping the social distance. From here came the idea of the project where it presents a design proposal for a shaded waiting bench on Campus based on meeting the aesthetic appeal and functional needs to design a visual content befitting the identity of Pharos University in Alexandria.



## Project Summary:

### ❖ Project Idea:

The project main idea lies in re-thinking the campus square that holds the CIB bank and all the university faculties, through introducing a design proposal of shaded waiting benches that provides protection and shelter to users from intense sunlight or rain, provided with several fixed side tables, which can be used in writing or for using students laptops provided with several electric sources where some students can join their on line lectures during their semesters.

### ❖ Project Phases:

- Designing shaded waiting seating units in the campus square with a contemporary vision that provides protection and shelter to users from weather fluctuations, whether intense sunlight or rain instead of jamming under the faculties' entrance and atrium.
- Designing a complete integrated designed unit that is convenient for students to use within their online lecture's using their mobile phones or laptops or waiting between lectures, providing it with some fixed side tables and electrical sources to use.
- Introducing the specialization of Decor Department at the Faculty of Arts and Design, Pharos University to civil institutions.
- Enhance the capabilities of Egyptian youth in the field of specialty and relatively meeting the market needs.
- Encourage the student to progress in such competitions initiated to enhance the competitive ability within the field of environmental furniture design.

### ❖ Project Studies:

#### First: The theoretical and practical study within the course contents

The theoretical study of the project concerns studying the concept of the shaded design unit proposal in addition to studying the importance of furniture design to meet users' needs even relevant to aid local society and environment. This is addressed through main points:

- 1- The student's selection of the most convenient furniture design according to the vision and needs of the University Students and Visitors.





- 2- Developing the idea of the design through different sketches to reach the final idea selected.
- 3- Determining the specifications of the shaded waiting benches and the availability to repeat it on campus square within suitable circulations between them.
- 4- Preparing the structural drawings of the furniture design needed to perform the design proposal.

### **Second: The practical study through simulation and availability to perform the Design Proposal:**

The practical study for the design proposal of the shaded waiting bench on campus

concerns:

- 1- Studying the suggested materials and fixation techniques of the design proposal on campus.
- 2- Mass planning for the campus student square relative to the shaded bench repetition.
- 3- Simulation, through computer aided programs by placing the designed proposal in the campus square with the planned vision to study its suitability on the university campus to suit the objectives of the project.

### **4.3 Towards Sustainable Development of Tourism Beaches: The case of El Mandarah Beach, Egypt**

This proposed project aims to develop an applicable, generic model and a practical action plan, which can be applied to all Alexandrian beaches and communities, in order to close the gap between the desired quality and the current state of how closely the management, employees, and visitors to these beaches adhere to the principles and international sustainability standards.

Furthermore, following an examination of the governorate of Alexandria's current sustainability initiatives, our aim is to educate local officials and the community on the concepts and principles of sustainability best practises, particularly during and after the corona virus pandemic, in order to raise awareness.

## **Project Phases:**

In the various phases of the study, the project used diverse methodologies such as interviews, field visits, surveys, and workshops, as shown in the model.

The phases began with an examination of the current state of sustainable tourist development along the coast of Alexandria. Then, from the Alexandria seacoast, choose three beaches, Gleem, Anfhoshy, and El Mandara, one of which will be chosen based on criteria. Finally, adopting important steps to enhance sustainability along the Alexandria shore, such as the ones listed below:

- To facilitate the field visit, communicating with local authorities about the need for them to approve and provide access to allow the conduction of the field study smoothly, as well as the necessity for them to shine scientific light on it.
- Executing crucial and applicable criteria that express the study's pillars.
- By conducting the study survey, we are aiming for local community comments and opinions that focus on their intellectual background and convey those actual situations of the examined beaches.
- Following the revision of the local community perspective, the next step is to create an action plan that will make it simple for local governments to implement

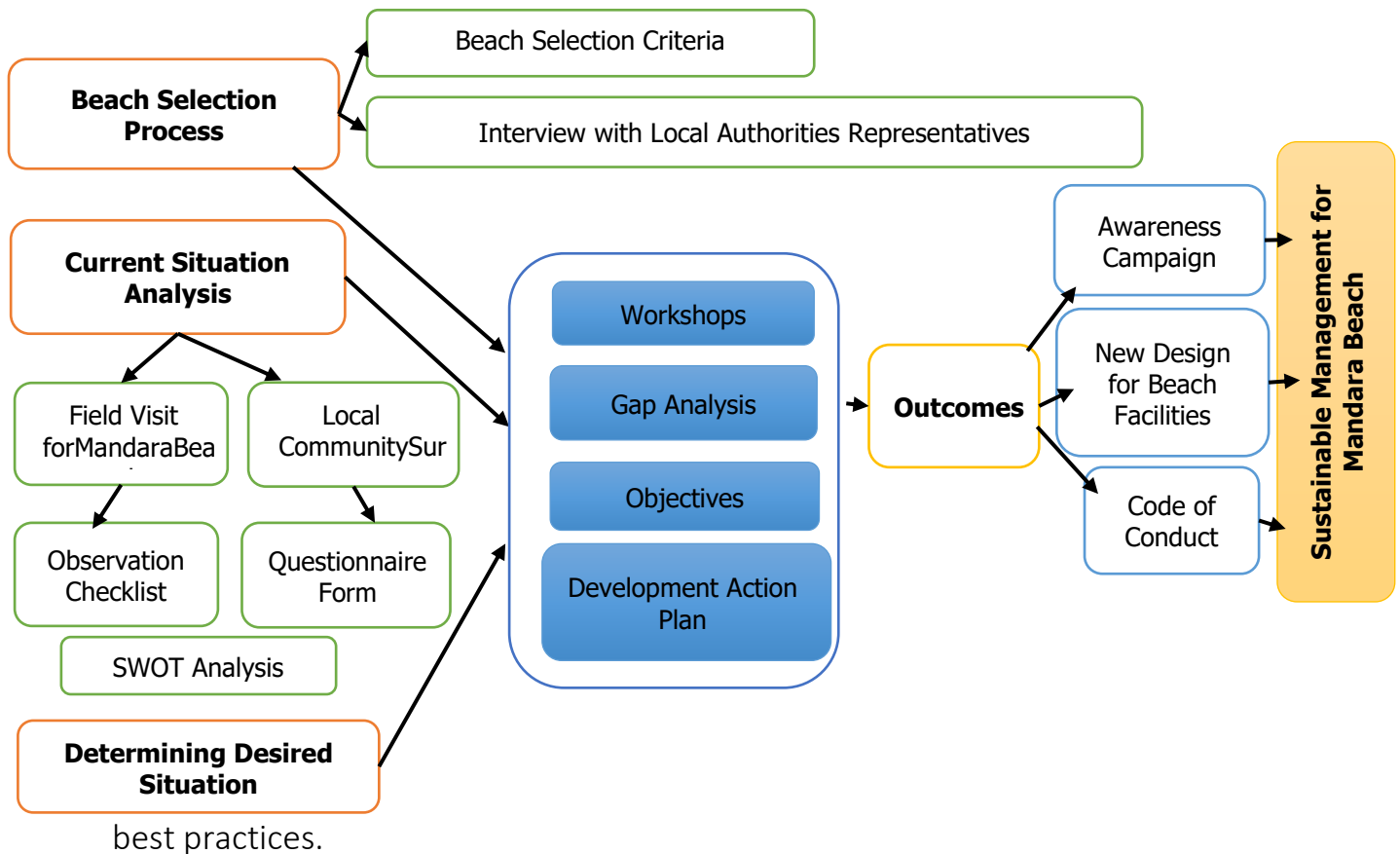



From Abu Qir in the east to Al-Alamein and Sidi Abdul Rahman in the west, Alexandria beaches run for 140 kilometers along the Mediterranean Sea. The beaches of Alexandria are a popular tourist destination; each year, over one million local summer visitors and about five million inhabitants enjoy the summer season in Alexandria.

## 5 For SDG 16 the students the students participated in the following project

### 5.1 How rightful it is for countries to force it's citizens to take the vaccine

- The first aspect: Social responsibility

We launched an awareness campaign about the dangers of the virus and the necessity of receiving the vaccine, as well as offering a reward to those who are about to receive the vaccine. We named our reward card (Coronoply) as the inspiration was derived from the game (Monopoly), and the campaign is called (Get Out of Isolation).

- The second aspect: The legal role

The university is intervening in the lawsuit filed before the Administrative Court against the Prime Minister, where a number of plaintiffs are clearly impacted by the requirement to submit a certificate of vaccination when they enter their workplaces.

- The third aspect: The medical aspect

In our research, we referred to documented opinions of medical professionals in this matter, headed by the World Health Organization.

We will present this study by presenting two opposing opinions, each with its own arguments and proofs.

- ❖ Recommendations

At the end of our study, and after confirming the different opinions presented by the two parties, we conclude with the following recommendations:



**First:** We demand that Pharos University accept joining the lawsuit filed with the prepared defense memorandum.

**Second:** We ask the state to provide an advantage for the elderly, who are – certainly – fertile ground for the virus and are not obligated in any way to take the vaccine.

We have tried in every way possible during our campaign to provide integrated medical teams to go to the homes of the elderly to give them the vaccine, but it was not possible for us to do so because of the strict procedures the state has set up regarding this matter, represented by the Egyptian Ministry of Health.

**Third:** Launching an intensive awareness campaign for the age group from 15 to 18, who had the opportunity to be vaccinated from the 7<sup>th</sup> November.



## 6 International Cooperation and partnerships for Sustainable Development:

International Partnerships (MOUs): Pharos University established international relations with the following renowned universities and research centers:

| Faculty   | International Institute                     | Contributing to SDG                         |
|---|---|---|
| Pharmacy  | Université de Picardie Jules Verne UPJV     | SDG 3                                       |
| Dentistry, Pharmacy and Business                            | The University of Naples Federico II, Italy |   |
| Pharmacy  | Aston University, Birmingham, UK            | SDG 3                                       |
|   | Kingston University, London, UK             |   |
|   | Leipzig, Germany                            |   |
| Engineering   | Royal Institute of Technology KTH – Sweden  | SDG 6, SDG 7, SDG 11, SDG 12, SDG 13        |
|   | RWTH Aachen                                 | SDG 6, SDG 7, SDG 11, SDG 12, SDG 13        |
| Allied Medical sciences                                     | FH Campus Wien                              | SDG3  |
| Physical Therapy,   | Goethe' University , Frankfurt, Germany     | SDG3  |
| Humanities (business and entrepreneurship), and engineering | Heilbronn University HHN Germany            | SDG 6, SDG 7, SDG 8, SDG 11, SDG 12, SDG 13 |
|   | Tomas Bata University (TBU), Czech Republic | SDG 6, SDG 7, SDG 11, SDG 12, SDG 13        |
|   | University of Alabama in Birmingham, USA    | SDG 6, SDG 7, SDG 11, SDG 12, SDG 13        |
|   | Hunan Agriculture University - China        | SDG 6, SDG 7, SDG 11, SDG 12, SDG 13        |
|   | Belarusian State University                 | SDG 6, SDG 7, SDG 11, SDG 12, SDG 13        |
|   | Universidad de Sevilla                      | SDG 7,SDG 11                                |



| Faculty                                     | International Institute                                | Contributing to SDG  |
|---|--|----------------------|
| Tourism                                     | City University- Malaysia                              | SDG 8, SDG 9, SDG 11 |
|   | Ulster University                                      | SDG 8, SDG 9, SDG 11 |
| Humanities (business and entrepreneurship), | JAMK University of Applied Sciences, Finland           | SDG 8, SDG 9, SDG 11 |
| Humanities (Tourism and language)           | Technological University Dublin (TU Dublin), Ireland   | SDG 8                |
|   | Tomas Bata University (TBU), Czech Republic            | SDG 8                |
|   | TOI-OHOMAI   | SDG 8                |
| Humanities (Law)                            | Sciences Po Lille - France                             | SDG 16               |
| Humanities (Art and design)                 | Kingston University, London, UK                        | SDG 11               |
| Pharmacy                                    | Aston University, Birmingham, UK                       | SDG 3                |
| Physical Therapy, Applied Medical           | University of Oradea-Romania                           | SDG 3                |
| Humanities (Optometry)                      | Lincoln University College, Malaysia                   | SDG 9, SDG 11        |
|   | University of Missouri–Kansas City (UMKC), USA         | SDG 9.SDG 11         |
| Humanities (Mass communication)             | East Carolina University, USA                          | SDG 17               |
| Humanities (Languages), Tourism             | The British Council                                    | SDG 17               |
|   | Norwich Institute for Language Education, UK           | SDG 17               |
|   | Universidad De Castilla-La Mancha-Spain                | SDG 5, SDG 17        |
|   | University of Naples Federico                          | SDG 5, SDG 17        |
|   | Cambridge- ESOL (English Language Centre (ELC)         | SDG 5, SDG 17        |
|   | Beijing Languages and Culture University (BLCU), China | SDG 5, SDG 17        |
|   | Trinity College  | SDG 17               |
|   | Guangdong University of Foreign studies                | SDG 5, SDG 17        |
|   | University of A Coruña                                 | SDG 5, SDG 17        |
|   | AMIDEAST   | SDG 5, SDG 17        |
|   | University of Leicester                                | SDG 5, SDG 17        |





## General MOUs

|  |  |
|--|--|
| Agence Universitaire Francophonique                  |  |
| Salamanca University, Spain                          |  |
| Institute Of International Education (Lotus Program) |  |
| USAID projects                                       |  |
| Aristotle University of Thessaloniki, Greece         |  |
| University of Eastern Finland UEF                    |  |
| University Senghor, Alexandria                       |  |
| Durban University of Technology                      |  |



## Conferences

### List of conferences that were held in Pharos university

| Faculty                               | Date              | Conference   | Related SDG |
|---------------------------------------|-------------------|--|-------------|
| Pharmacy and Drug Manufacturing       | March 11-12, 2020 | 2nd PUA International Conference - Multidisciplinary Approaches in Pharmaceutical Sciences ICMAPS / 2020             | SDG 3       |
| Financial and Administrative Sciences | April 4-8, 2020   | Sixth International Conference of Business Innovation & Economic Sustainability Challenges - TU Dublin               | SDG 8       |
| Engineering                           | March 1-2, 2022   | The Third International Conference on New Trends for Sustainable Energy, ICNTSE 2021 (ONLINE) - From Waste To Energy | SDG 7       |
| Languages and Translation             | March 11-12, 2022 | Translation and Teaching English: Challenges and Perspectives - University College Dublin                            | SDG 4       |
| Pharmacy and Drug Manufacturing       | May 14, 2022      | 3rd PUA International Conference in Pharmaceutical Sciences  | SDG 3       |
| Applied Health Sciences Technology    | May 22, 2022      | Nutrition and health and disease the update Dietetic Practice  | SDG 3       |

### 6.1.1 Third International Conference on New Trends in Sustainable Energy (ICNTSE-2021) online

<https://www.pua.edu.eg/third-international-conference-on-new-trends-in-sustainable-energy-icntse-2021-online/>

PUA's Faculty of Engineering organizes the Third International Conference on New Trends in Sustainable Energy (ICNTSE-2021) on 1-2 March 2022 via online conference. It is also worth mentioning that the Journal of King Saud University – Engineering Sciences (JKSUES) will publish a special edition for a selected group of the conference's research, which meet the journal's publishing requirements.



### 6.1.2 The Faculty of Languages and Translation held an international conference in collaboration with Trinity College, Dublin University

The Faculty of Languages and Translation held a 2-day international conference in collaboration with Trinity College, Dublin University entitled "Translation and Teaching: Challenges and Perspectives". The conference had great feedback from 140 attendees from all around Egypt as well as attendees



from Trinity College virtually. The conference dealt with a variety of topics on invitation methods of teaching and recent research on Translation. All abstracts were published in the conference procedures as well as keynote speakers'



abstracts. The conference held parallel sessions to cover a variety of topics. The attendees were thrilled by the organization, topics, and networking vibes.

Thank you note to all our sponsors: Capital Professional Development, American Council Egypt, IDP, and ECL Cambridge. The conference help SDG4

### **6.1.3 Faculty of pharmacy 2<sup>nd</sup> international conference 11<sup>th</sup> -12<sup>th</sup> , March 2020**

<http://beta.pua.edu.eg/icmaps/>

The Pharmaceutical sciences are a group of interdisciplinary areas involved with the design, action, delivery, disposition, and use of drugs aiming to uplift the quality of life and public health. Bearing this mission, Faculty of Pharmacy and Drug Manufacturing, Pharos University in Alexandria, Egypt has the pleasure to cordially invite you to join the Second PUA International Conference on Multidisciplinary Approaches in Pharmaceutical Sciences, taking place on March 11-12, 2020 at Pharos University in Alexandria, Egypt.

The goal of the conference is to bring together pharmaceutical groups of national and international academics, researchers, community and industrial pharmacists and clinicians to have an interchangeable break- through ideas related to the most recent advances in pharmaceutical technologies. Challenges and opportunities will be discussed through exchange of ideas and collaboration

## 6.2 Partnerships for sustainability

### 6.2.1 Activities with Africa in the field of Sustainable Development

Pharos university is keen to have planned actions to recruit students/staff/faculty from under-represented group particularly Africa. Recently the university took steps in the following activities:

### 6.2.2 Pharos University in Alexandria organizes a virtual “Design thinking and Ideation camp” through E-Club

PUA in cooperation with the African Union and the Egyptian Academy of Scientific Research and Technology, the camp targets students, and graduates of PUA and African Union universities. The camp is held from 26-29 July 2021 aiming at motivating African youth towards “Social Entrepreneurship” to trigger innovative ideas that serve the goals of development and sustainability in the African societies.

<https://www.pua.edu.eg/intra-africa-2063-competition/>

In the same context, Pharos University in Alexandria organizes a virtual “Design thinking and Ideation camp” through Eclub PUA in cooperation with the African Union and the Egyptian Academy of Scientific Research and Technology, the camp targets students, and graduates of PUA and African Union universities.



The poster for the Intra-Africa 2063 Competition features a vibrant background with a map of Africa and zebra stripes. At the top, it lists logos for E-Club, Pharos University in Alexandria, and the African Union. The main title is "Intra-Africa 2063 Competition" with the subtitle "virtual workshops hand in hand by PUA, ASRT & AAU" and dates "26/7 - 29/7/2021". It specifies time zones: GMT+10am Egypt Time, 9am Nigerian Time, 10am Southern African Time, 11am East African Time. Key features include "Free Event - Free Registration - Attendance Certificate - Held in English", a registration deadline of 13/7, and an acceptance confirmation e-mail by 20/7. The event objectives are to create innovative scientific ideas or research projects to serve African societies through four-day workshops aligned with the 2063 agenda. A key objective is "The Establishment of an AFRICAN Digital, Distance Learning University Social ENTREPRENEURSHIP". Specialized trainers will qualify students to work on innovative ideas, and teams will pitch to a judging panel for 1<sup>st</sup>, 2<sup>nd</sup>, and 3<sup>rd</sup> place winners. "Social entrepreneurship" is defined as developing and implementing solutions to social, cultural, or environmental issues, with fields including illness, poverty, illiteracy, environmental destruction, and human rights. Prizes include: Platinum (Language + Soft skills), Golden (Soft skills), and Silver (Traditional Egyptian Kitchen course or Dubbing and Voice over). A registration link is provided at the bottom right.

The camp is held from 26-29 July 2021 aiming at motivating African youth towards “Social Entrepreneurship” to trigger innovative ideas that serve the goals of development and sustainability in the African societies.



Pharos University in Alexandria  
Vice President for Graduate Studies & Research  
**International Ranking committee**



<https://www.pua.edu.eg/%d9%85%d8%a8%d8%a7%d8%af%d8%b1%d8%a9-%d8%aa%d9%81%d8%b9%d9%8a%d9%84-%d8%aa%d8%b7%d9%84%d8%b9%d8%a7%d8%aa-%d8%a3%d8%ac%d9%86%d8%af%d8%a9-%d8%a7%d9%84%d9%82%d8%a7%d8%b1%d8%a9%d8%a7%d9%84%d8%a3%d9%81/>





### 6.2.3 PUA participates in the 15th General Conference of the Association of African Universities “ “TheFuture of African Higher Education in Africa”

<https://www.pua.edu.eg/pua-participates-in-the-15th-general-conference-of-the-association-of-african-universities/>

Pharos University in Alexandria (PUA) has participated in the 15th General Conference of the Association of African Universities that held virtually from 5-8 July 2021 hosted by. Dr. Khaled Abdel Ghaffar, Minister of Higher Education and Scientific Research. His excellency has participated a speech and on Monday 5th of July in the 15th Conference of African University Leaders, organized by the Federation of African Universities via video conferencing technology.

At the beginning of his speech, the Minister expressed his happiness to participate in the conference held under the patronage of the Ghanaian President, pointing out the importance of working to bring about a qualitative move in higher education in Africa, to promote social and economic growth, by creating a better environment for higher education and scientific research and building modern systems of science, technology, and innovation.

The coordinator of African relations of PUA, Dr. Nourhan Al-Haridi, participated in the various sessions of the conference activities as a representative of the university, based on the support of Pharos University in Alexandria and its role in developing and raising the efficiency of higher education and scientific research in Africa

### 6.2.4 Pharos University Participated in Africa Higher Education Webinar

The Webinar entitled “Towards Linked Africa Higher Education: Windows of Opportunities” organized under the supervision of the Association of African Universities’ North Africa Regional Office “AAU-NARO”. This was held on Wednesday, 17 March 2021.

<https://www.pua.edu.eg/pharos-university-participated-in-africa-higher-education-webinar/>

It is worth mentioning that more than 20 African universities participated in the webinar including Pharos University which was represented by Prof. Boshra Salem, Dean of Postgraduate Studies and Research in Pharos University and Dr. Mennatallah Gowayed, the PUA International Relations Coordinator.



During the webinar, on behalf of PUA president Prof. Boshra Salem gave a speech to representatives of “NARO” and participating universities and thanked “NARO” for inviting Pharos University to be a part of activities to mark NARO’s two years’ anniversary. This was followed by a presentation by Dr. Mennatallah Gowayed on PUA international relations specially with the Corona circumstances. It is worth mentioning that Pharos University is the only Egyptian university presented the topic of internationalization and international relations.

[Pharos University joins the Association of African Universities](#)

<https://www.pua.edu.eg/pharos-university-joins-the-association-of-african-universities/>

### 6.2.5 Cooperation with KTH university in the field of quality education

<https://www.pua.edu.eg/pharos-university-organized-meetings-with-kth-royal-institute-of-technology/>

The International Relations Department organized many Zoom meetings between the academic staff of the Faculty of Engineering and KTH Royal Institute of Technology on 22-23 March, in order to track engineering students’ exams. During these meetings, the exams’ models and quality standards were discussed. It is worth mentioning that the teaching schedule has been approved for the next semester (spring 2020/2021).





## 6.2.6 Cooperation Project between University of Wolverhampton of UK and Pharos University in Alexandria

<https://www.pua.edu.eg/cooperation-between-wolverhampton-of-uk-and-pharos-university/>

Joint Cooperation Project between University of Wolverhampton of UK and Pharos University in Alexandria

Advancing apprenticeship learning in Trans-National Education (TNE)

the Faculty of Engineering and the Construction Engineering and Management Department were honored to receive and organize the scientific forum entitled ”

Advancing apprenticeship learning in Trans-National Education (TNE) as one of the activities of the joint project between Pharos University in Alexandria and the

University of Wolverhampton and funded by

the British Council from the 25th to the 28th of July 2022 where a team from the University of Wolverhampton visited Pharos University in Alexandria and discussed the ways of Cooperation between in the presence of a selection of faculty members, representatives of the Syndicate of the Egyptian Engineers and experts and specialists from industry.



### **6.2.7 Cooperation Protocol with TÜV AUSTRIA**

For supporting the academic study of the Faculty students, providing them with practical and field experiences, and linking the curricula with industrial fields to achieve the sought integration, Prof. Dr. Mohamed Gaber Abou Ali, Dean of the Faculty of Engineering along with a group of the Faculty professors welcomed Mr. Osama El-Sayed Ibrahim, Regional Director of TÜV AUSTRIA, on Wednesday, January 26, 2022. The meeting included the signing of a cooperation protocol between PUA's Faculty of Engineering and TÜV Austria.



This protocol included providing training opportunities and specialized workshops for the Faculty students, providing experienced staff to supervise the students' research and projects at the Faculty, which would provide solutions to some of the industry's problems. In a similar context, the Faculty organizes training programs, workshops, conferences and seminars for the company's employees. It also provides academic consultations in light of the experience of its professors to solve some of the company's problems, which requires conducting research and studies in this regard.

### **6.2.8 Faculty Of Pharmacy Organizes two workshops**

The faculty of Pharmacy and Drug Manufacturing, Organized two workshops on 9-10 March 2020 from 9 am to 4 pm. The first workshop is on "How to Implement Flipped Classroom Approach in University Courses" and delivered by Prof. Markku Saarelainen, a Professor of Physics at University of Eastern Finland (UEF) and a Professor of Practice at Tampere University (TAU) in Finland. Meanwhile, the second workshop which is about "Synthesis, Processing, Characterization and Functional Validation of Inorganic Nanomaterials for Bio-applications", is delivered by Prof. Muhammet Toprak, a Professor of Materials Chemistry, Nanochemistry Research Group in the KTH -Sweden.



### 6.2.9 An EU Funded project with six regional and international universities for sustainable development and preservation of heritage

<https://www.pua.edu.eg/tourism-and-hotel-management/sustainability-concept-applications/fund-projects/>

The Faculty of Tourism and Hotel Management heads a funded project by the European Union, in partnership

Université de Malte

Leeds Beckett University- United Kingdom o Middle East University – Jordan

Yarmouk University – Jordan o Suez Canal University

Fayoum University

The proposed project under the title “Cultural Heritage Virtual Education System” (CHVEs) aims to modernize and improve the educational process in the field of tourism and cultural heritage sciences in the faculties and institutes of higher education in Egypt, through the development of international scientific cooperation and the transfer of knowledge. This project is considered of great value and importance regarding the issue of supporting the process of sustainable development and the preservation of the cultural and urban heritage of countries.

### 6.3 International Mobilities contributing to different SDGs

| Name                 | Title            | Faculty                      | Host University              | Year | SDG          |
|----------------------|------------------|------------------------------|------------------------------|------|--------------|
| Mohmaed Elkoly       | Lecturer         | Engineering                  | KTH, Sweden                  | 2022 | SDG 9        |
| Alaa Mahmoud Khalil  | Lecturer         | Engineering                  | KTH, Sweden                  | 2022 | SDG 9        |
| Tamer Mohamed        | Lecturer         | Tourism and hotel management | Universidad de coruña, Spain | 2022 | SDG 13       |
| Lamiaa Ibrahim Fathy | Assoc. Professor | Tourism and hotel management | JAMK University Finland      | 2021 | SDG 13       |
| Eslam Ibrahim Fathy  | Assoc. Professor | Tourism and hotel management | JAMK University Finland      | 2021 | SDG 13       |
| Rasha Elbyaa         | Professor        | Pharmacy                     | Eastern Finland , Finland    | 2022 | SDG 3, SDG 4 |
| Gihan Labib          | Assoc. Professor | Pharmacy                     | Eastern Finland , Finland    | 2022 | SDG 3, SDG 4 |
| Menna gwaed          | Assoc. Professor | Pharmacy                     | Eastern Finland , Finland    | 2022 | SDG 3, SDG 4 |





| Name             | Title                 | Faculty                                     | Host University                                       | Year | SDG             |
|------------------|-----------------------|---|---|------|-----------------|
| Rewan Medhat     | Demonstrator          | Pharmacy                                    | Eastern Finland ,<br>Finland                          | 2022 | SDG 3,<br>SDG 4 |
| Omnia Ashraf     | Demonstrator          | Pharmacy                                    | Eastern Finland ,<br>Finland                          | 2022 | SDG 3,<br>SDG 4 |
| Rania Raof       | Lecturer              | Art and design                              | Aristotle<br>University of<br>Thessaloniki,<br>Greece | 2022 | SDG 11          |
| Nada Kamel       | Lecturer              | Art and design                              | Aristotle<br>University of<br>Thessaloniki,<br>Greece | 2022 | SDG 11          |
| Mohamed<br>Osama | Assistant<br>lecturer | Art and design                              | Aristotle<br>University of<br>Thessaloniki,<br>Greece | 2022 | SDG 11          |
| Ireni Rober      | Assistant<br>Lecturer | Financial and<br>Administrative<br>Sciences | TU, Dublin  | 2020 | SDG 8           |
| Omnia<br>Mohamed | Assistant<br>Lecturer | Financial and<br>Administrative<br>Sciences | TU, Dublin  | 2020 | SDG 8           |



